

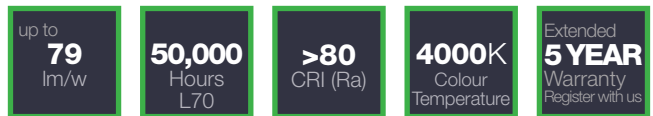

Stylish and vandal resistant, the new Fern-Howard Pacific is a weather proof and UV resistant LED Bulkhead. It combines robustness and pleasant light in a modern, dynamic design.



FEATURES

- Energy efficient LED luminaire with a life span of 50,000 hours (L70)
- Contemporary round shape
- Robust Polycarbonate body in white
- Opal polycarbonate diffuser provides pleasing light
- UV resistant and corrosion free
- IP65 protection against dust and water

Built-in Microwave Sensor option available - to further reduce energy use.



SIMPLE TO INSTALL AND USE

- Slot-in geartray for easy installation
- Complete with security screws (key provided)
- Wall or ceiling mountable
- Interior and exterior use

TYPICAL APPLICATIONS

- Car parks
- Walkways
- Stairwells and corridors
- Local Authorities and Housing Associations
- Commercial buildings

PACIFIC LED



TECHNICAL INFORMATION

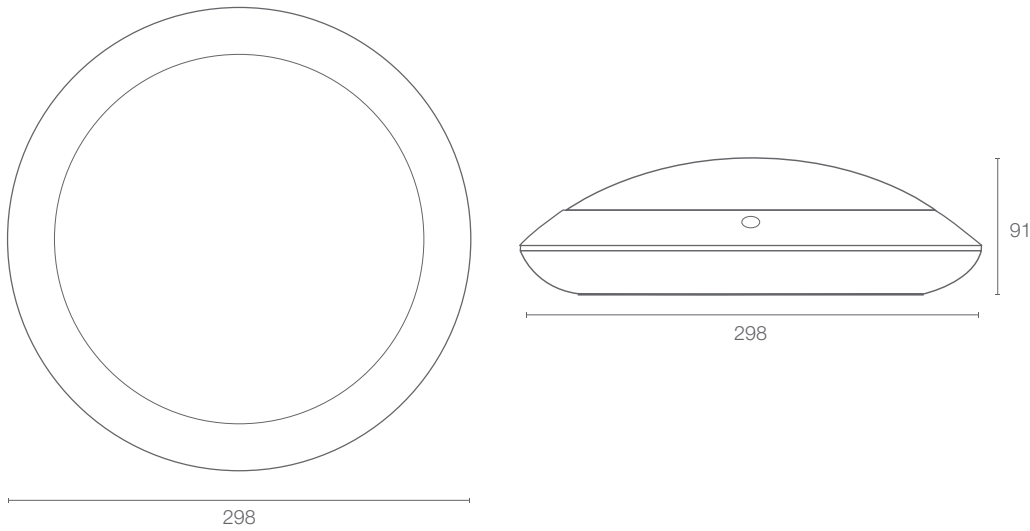

Dimensions:
Ø 298 x 91mm

Weight:
0.8kg

Mounting type:



Base Colour Options:

White base

Diffuser Options:

Opal Diffuser

LIGHT DISTRIBUTION

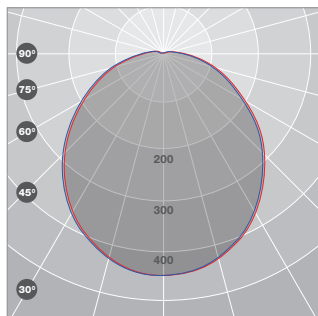

cd/klm $\eta = 100\%$
— C0 / C180 — C90 - C270

Photometric files at www.fernhoward.com

STANDARDS

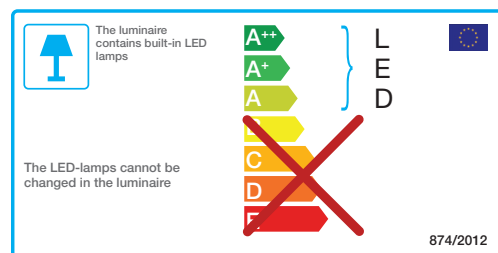

ORDERING GUIDE

Standard Product Code		Light Management Options Suffix									Performance Data**		
	Base Colour	Diffuser Option	DALI	Dimming	Corridor Function	3hr Emergency	Self-Test	DALI Emergency	Microwave Sensor	PhotoCell	Lumen Output lm	Wattage W	Efficacy lm/W
Pacific LED													
FHBL268-083	W	OP	-	-	-	-	-	-	MS	-	830	10.5	79

FHBL268-083 - W - OP - MS

Example Code: Pacific, White, Opal with Microwave Sensor

** Efficacy can vary depending on Light Management Option chosen

50,000
Hours
L70

>80
CRI (Ra)

4000K
Colour
Temperature

Luminaires are manufactured and tested in accordance with BS EN60598.
Incorporated control gear and components comply with BS/VDE standards.
Luminaires are tested in accordance with IES LM-79-08.